

DM74LS74A

Dual Positive-Edge-Triggered D Flip-Flops with Preset, Clear and Complementary Outputs

General Description

This device contains two independent positive-edge-triggered D flip-flops with complementary outputs. The information on the D input is accepted by the flip-flops on the positive going edge of the clock pulse. The triggering occurs at a voltage level and is not directly related to the transition time of the rising edge of the clock. The data on the D input may be changed while the clock is LOW or HIGH without affecting the outputs as long as the data setup and hold times are not violated. A low logic level on the preset or clear inputs will set or reset the outputs regardless of the logic levels of the other inputs.

Ordering Code:

Order Number	Package Number	Package Description
DM74LS74AM	M14A	14-Lead Small Outline Integrated Circuit (SOIC), JEDEC MS-120, 0.150 Narrow
DM74LS85ASJ	M14D	14-Lead Small Outline Package (SOP), EIAJ TYPE II, 5.3mm Wide
DM74LS74AN	N14A	14-Lead Plastic Dual-In-Line Package (PDIP), JEDEC MS-001, 0.300 Wide

Devices also available in Tape and Reel. Specify by appending the suffix letter "X" to the ordering code.

Connection Diagram

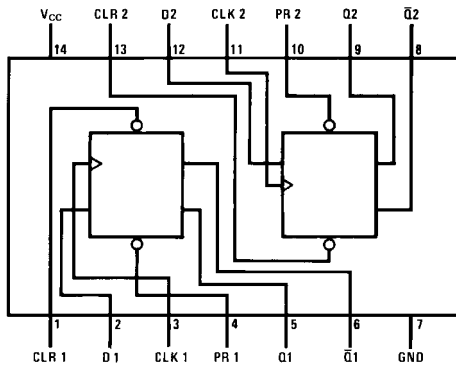

Function Table

Inputs				Outputs	
PR	CLR	CLK	D	Q	\bar{Q}
L	H	X	X	H	L
H	L	X	X	L	H
L	L	X	X	H (Note 1)	H (Note 1)
H	H	↑	H	H	L
H	H	↑	L	L	H
H	H	L	X	Q_0	\bar{Q}_0

H = HIGH Logic Level

X = Either LOW or HIGH Logic Level

L = LOW Logic Level

↑ = Positive-going Transition

Q_0 = The output logic level of Q before the indicated input conditions were established.

Note 1: This configuration is nonstable; that is, it will not persist when either the preset and/or clear inputs return to their inactive (HIGH) level.

Absolute Maximum Ratings(Note 2)

Supply Voltage	7V
Input Voltage	7V
Operating Free Air Temperature Range	0°C to +70°C
Storage Temperature Range	-65°C to +150°C

Note 2: The "Absolute Maximum Ratings" are those values beyond which the safety of the device cannot be guaranteed. The device should not be operated at these limits. The parametric values defined in the Electrical Characteristics tables are not guaranteed at the absolute maximum ratings. The "Recommended Operating Conditions" table will define the conditions for actual device operation.

Recommended Operating Conditions

Symbol	Parameter	Min	Nom	Max	Units
V_{CC}	Supply Voltage	4.75	5	5.25	V
V_{IH}	HIGH Level Input Voltage	2			V
V_{IL}	LOW Level Input Voltage			0.8	V
I_{OH}	HIGH Level Output Current			-0.4	mA
I_{OL}	LOW Level Output Current			8	mA
f_{CLK}	Clock Frequency (Note 3)	0		25	MHz
f_{CLK}	Clock Frequency (Note 4)	0		20	MHz
t_W	Pulse Width (Note 3)	Clock HIGH	18		ns
		Preset LOW	15		
		Clear LOW	15		
t_W	Pulse Width (Note 4)	Clock HIGH	25		ns
		Preset LOW	20		
		Clear LOW	20		
t_{SU}	Setup Time (Note 3)(Note 5)	20 \uparrow			ns
t_{SU}	Setup Time (Note 4)(Note 5)	25 \uparrow			ns
t_H	Hold Time (Note 5)(Note 6)	0 \uparrow			ns
T_A	Free Air Operating Temperature	0		70	°C

Note 3: $C_L = 15$ pF, $R_L = 2$ k Ω , $T_A = 25^\circ\text{C}$, and $V_{CC} = 5\text{V}$.

Note 4: $C_L = 50$ pF, $R_L = 2$ k Ω , $T_A = 25^\circ\text{C}$, and $V_{CC} = 5\text{V}$.

Note 5: The symbol (\uparrow) indicates the rising edge of the clock pulse is used for reference.

Note 6: $T_A = 25^\circ\text{C}$ and $V_{CC} = 5\text{V}$.

Electrical Characteristics							
over recommended operating free air temperature range (unless otherwise noted)							
Symbol	Parameter	Conditions	Min	Typ (Note 7)	Max	Units	
V_I	Input Clamp Voltage	$V_{CC} = \text{Min}, I_I = -18 \text{ mA}$			-1.5	V	
V_{OH}	HIGH Level Output Voltage	$V_{CC} = \text{Min}, I_{OH} = \text{Max}$ $V_{IL} = \text{Max}, V_{IH} = \text{Min}$	2.7	3.4		V	
V_{OL}	LOW Level Output Voltage	$V_{CC} = \text{Min}, I_{OL} = \text{Max}$ $V_{IL} = \text{Max}, V_{IH} = \text{Min}$ $I_{OL} = 4 \text{ mA}, V_{CC} = \text{Min}$		0.35	0.5	V	
					0.25		0.4
I_I	Input Current @ Max Input Voltage	$V_{CC} = \text{Max}$ $V_I = 7 \text{ V}$	Data		0.1	mA	
			Clock		0.1		
			Preset		0.2		
			Clear		0.2		
I_{IH}	HIGH Level Input Current	$V_{CC} = \text{Max}$ $V_I = 2.7 \text{ V}$	Data		20	μA	
			Clock		20		
			Clear		40		
			Preset		40		
I_{IL}	LOW Level Input Current	$V_{CC} = \text{Max}$ $V_I = 0.4 \text{ V}$	Data		-0.4	mA	
			Clock		-0.4		
			Preset		-0.8		
			Clear		-0.8		
I_{OS}	Short Circuit Output Current	$V_{CC} = \text{Max}$ (Note 8)	-20		-100	mA	
I_{CC}	Supply Current	$V_{CC} = \text{Max}$ (Note 9)		4	8	mA	
<p>Note 7: All typicals are at $V_{CC} = 5 \text{ V}, T_A = 25^\circ\text{C}$.</p> <p>Note 8: Not more than one output should be shorted at a time, and the duration should not exceed one second. For devices, with feedback from the outputs, where shorting the outputs to ground may cause the outputs to change logic state an equivalent test may be performed where $V_O = 2.125 \text{ V}$ with the minimum and maximum limits reduced by one half from their stated values. This is very useful when using automatic test equipment.</p> <p>Note 9: With all outputs OPEN, I_{CC} is measured with CLOCK grounded after setting the Q and \bar{Q} outputs HIGH in turn.</p>							
Switching Characteristics							
at $V_{CC} = 5 \text{ V}$ and $T_A = 25^\circ\text{C}$							
Symbol	Parameter	From (Input) To (Output)	$R_L = 2 \text{ k}\Omega$				Units
			$C_L = 15 \text{ pF}$		$C_L = 50 \text{ pF}$		
			Min	Max	Min	Max	
f_{MAX}	Maximum Clock Frequency		25		20		MHz
t_{PLH}	Propagation Delay Time LOW-to-HIGH Level Output	Clock to Q or \bar{Q}		25		35	ns
t_{PHL}	Propagation Delay Time HIGH-to-LOW Level Output	Clock to Q or \bar{Q}		30		35	ns
t_{PLH}	Propagation Delay Time LOW-to-HIGH Level Output	Preset to Q		25		35	ns
t_{PHL}	Propagation Delay Time HIGH-to-LOW Level Output	Preset to \bar{Q}		30		35	ns
t_{PLH}	Propagation Delay Time LOW-to-HIGH Level Output	Clear to \bar{Q}		25		35	ns
t_{PHL}	Propagation Delay Time HIGH-to-LOW Level Output	Clear to Q		30		35	ns